

FitFinder™ Lock Miter Bit User Manual (v9.0)

Create perfect-fitting lock miter joints easy and fast.

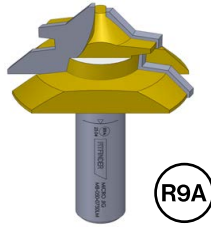

Lock Miter Bit 1/2" SHANK
MB-050-0750LM

! WARNING

Always wear safety glasses and hearing protection. Follow all safety precautions and use best practices. Microjig assumes no liability for products not sold by Microjig.

Stock size: 1/2" (12.7mm) minimum to 3/4" (19.07mm) or thicker.

Height gauge: Compatible with most standard height gauges. Works best when set using the **FitFinder 1/2 Gauge**.

Step 1

Set bit height to half of the stock using the FitFinder 1/2 gauge or other height gauge.

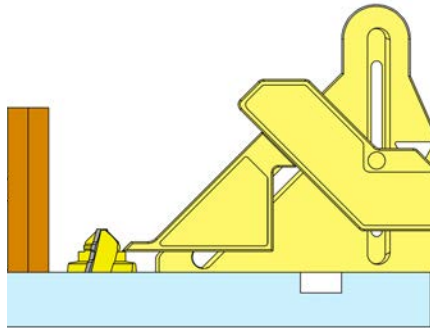

Step 3

Mill one half of the joint with the stock flat on the router table.

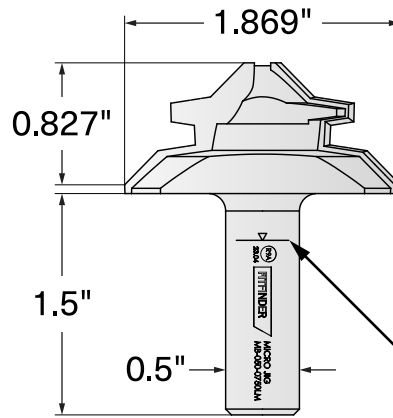
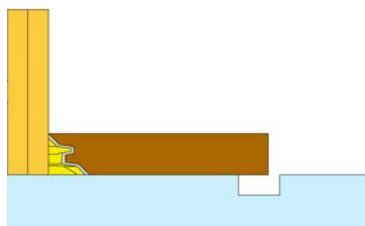

Operation

Recommended
10,000 RPM

Maximum
18,000 RPM

Laser etched safety collet line

Center Finding Platform

Lock miter bits must always be set to their center line.

Center Finding Platform (patent pending) takes the guesswork out of setting the bit height. This makes setup fast, easy, and accurate.

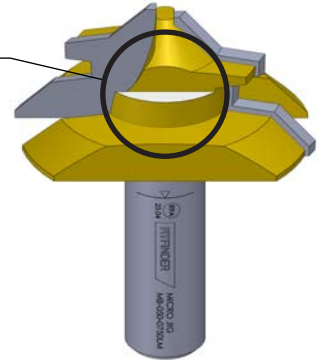

Built in "glue wells"

Unique glue well design prevents excess glue from holding your joint open, so the joints fit better together.

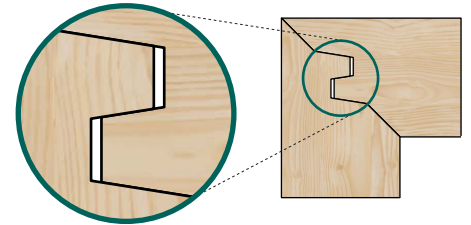

Step 2

Set the fence so the angle of the bit, the face of the fence and a ruler on top of the stock all meet.

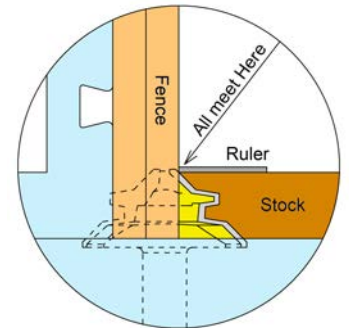

Step 4

Mill the second half of the joint with the stock against the fence.

